



2008 Field Setup

Make sure your robot is ready to compete!

Use this section as a guide to properly prepare your practice field and maximize your Mission strategy. Your team will need to:

- build the LEGO Mission Models using your *Field Setup Kit CD*. Your Field Setup Kit will ship to the address your registrant provided during [Team Registration](#). The Kit includes the Field Mat, the *Field Setup CD*, and instructions for constructing your LEGO Mission Models.
- carefully place your Field Mat (in the Field Setup Kit) on the flat surface
- add your Mission Models to the Field Mat
- practice!

The Table

- [Materials](#)
- [Parts](#)
- [Assembly](#)
- [Field Mat Placement](#)
- [Using Dual Lock](#)

Model Details

- [Levee Blocks](#)
- [Storm \(Wheel Roller\)](#)
- [People](#)
- [Underground Reservoir](#)
- [Ice Sheet](#)
- [House](#)
- [Cross-Pointers \(Interactive Models\)](#)
- [Flood Gate](#)
- [Carbon Dioxide And Money](#)
- [Core Drilling Rig](#)
- [Bicycle, Ice Buoy, Laptop, And Insulation](#)
- [Bear And Snowmobile](#)

Field Maintenance

- [Border Walls](#)
- [Field Mat](#)
- [Mission Models](#)

The Table

The robot game takes place on a specially designed table, so you will need to build one to practice on if you don't already have access to one. With safety, weight, height, and cost in mind, a simple design is offered here, but as long as your surface is smooth and your border walls are located properly, how you build the understructure is up to you. The construction is simple, but does require some shop skills. Build the light onto your table if your table will be placed in poor and/or variable lighting conditions.

At a tournament, two tables are placed back to back, forming a double-thick border between them. Since accurate setup requires that double-thick border, you're instructed to build it onto your practice table by adding a second one behind the first.

Materials

Material	Quantity (with light)	Quantity (no light)
Field Setup Kit	1	1
smooth plywood 96" X 48" X 1/4"	1	1
two-by-four, 8'	4	4
two-by-three, 8'	3	2
two-by-three, 10'	1	N/A
flat black paint	1 pt. or spray can	1 pt. or spray can
coarse drywall screws, 6 X 2-1/2"	1/2 lb.	1/2 lb.
saw horses, about 24" high and 36" wide	2	2
48" fluorescent shop light w/(2) 40-watt tubes	1	N/A

Parts

Part	Make From	Dimensions	Paint	Quantity (with light)	Quantity (no light)
table surface	plywood	96" X 48"	no	1	1
long border wall	two-by-four	96"	yes	3	3
short border wall	two-by-four	45"	yes	2	2
stiffener	two-by-three	48"	no	4	4
upright	two-by-three	48"	yes	2	N/A
cross beam	two-by-three	99"	yes	1	N/A
saw horse	kit	H » 24" W » 36"	no	2	2

Assembly

Step 1 Determine which face of the plywood is least smooth, and consider that the bottom face. On the bottom face, locate, clamp, and screw on the stiffeners (about every 18 inches).

Step 2 On the top face of the plywood, locate and clamp the border walls around the top perimeter. The wall-to-wall dimensions are important; they need to measure 93" by 45".

Step 3 With the help of another person, place this table top on short saw horses, milk crates, or anything else short and solid.

Step 4 If you're adding the light, center, clamp, level, and screw the uprights onto the outside face of the short border walls. With the help of another person, situate the cross beam on top of the two uprights and screw it down. Hang the shop light by its chains from the center of the cross beam. Tie some rope or a zip-tie loosely around the center of the shop light to hold the bulbs from falling if they should loosen.

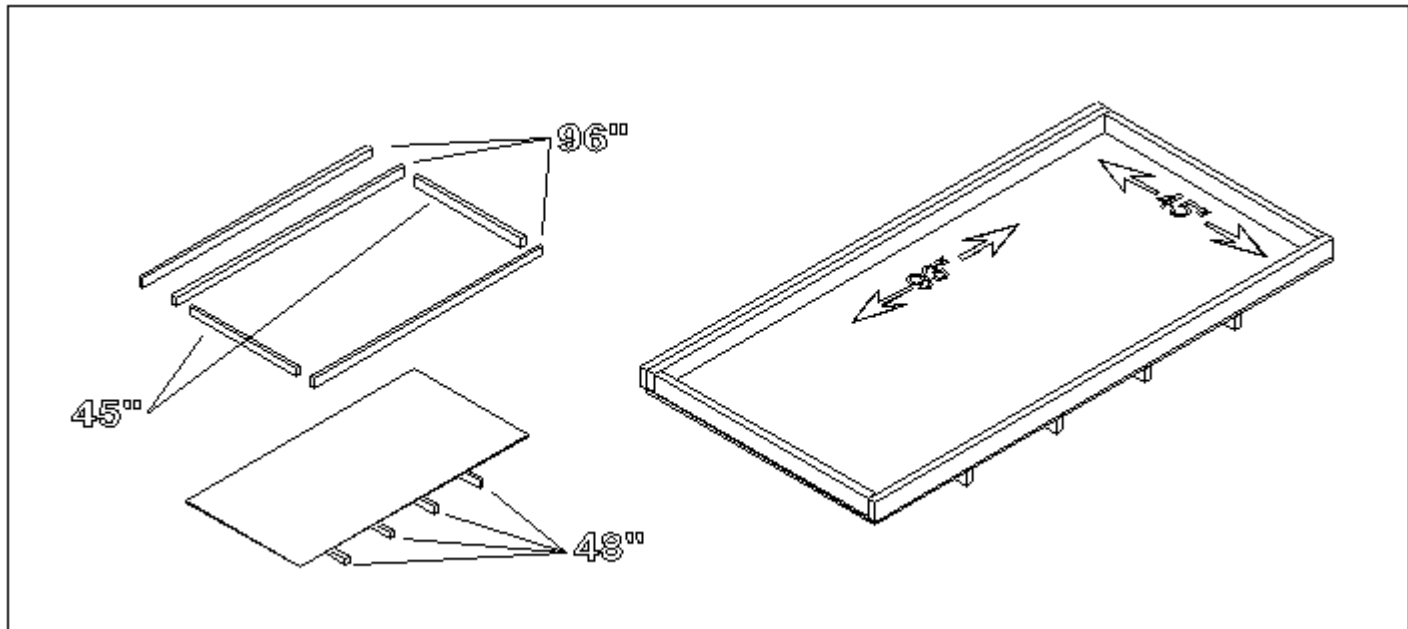

PRACTICE TABLE

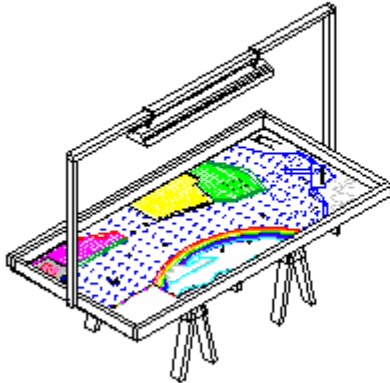

TOURNAMENT TABLE

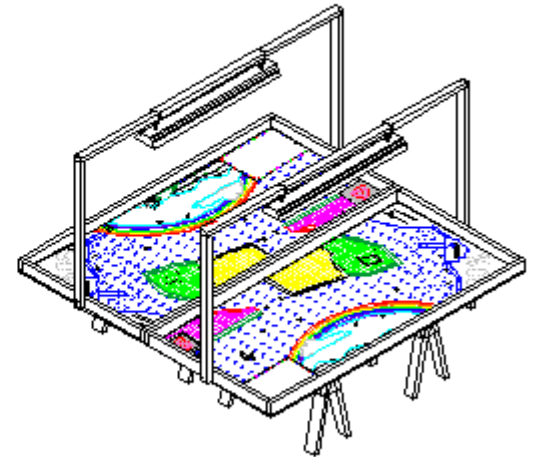

Field Mat Placement

Step 1 Vacuum the tabletop. Even the tiniest particle under the mat can give the robot trouble. After vacuuming, run your hand over the surface and sand or file down any protruding imperfections you find. Then vacuum again.

Step 2 Never unroll the mat in an area where it could pick up particles. On the vacuumed surface, unroll the mat and position it so the image is up and the area with logos (BASE) is at the southwest of your surface. (The south edge should be one to which you have easiest access).

Step 3 Slide and align the mat so there is no gap between the southwest corner's edges of the mat and the corresponding southwest border walls. Gaps are expected and acceptable at the north and east edges.

Step 4 With help from another person, pull the mat at opposite ends, then massage out any waviness from west to east and re-check the requirement of Step 3. It is expected that some waviness will persist, but that should relax over time. Some teams use a hair dryer to speed the relaxation of the waviness.

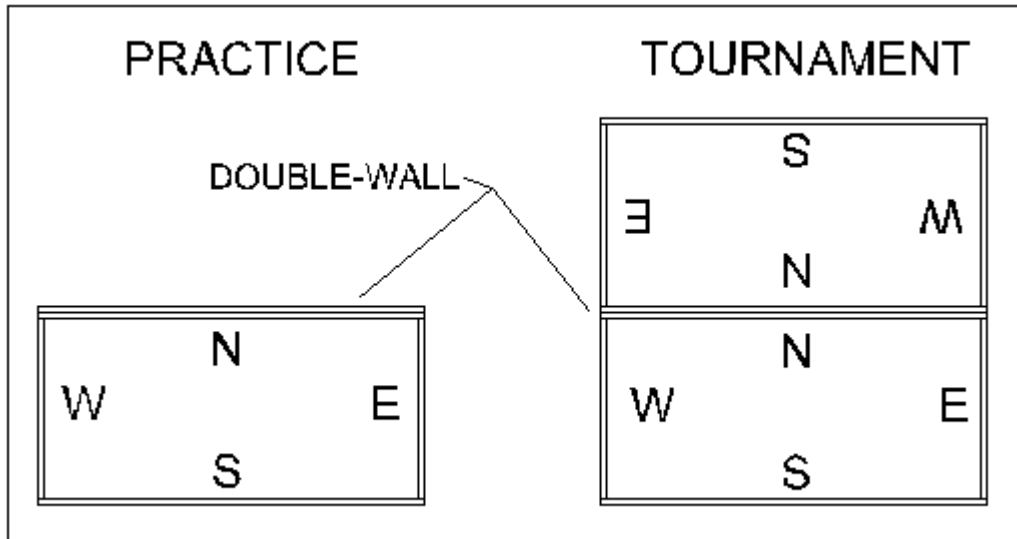

Using Dual Lock

When a model's placement requires Dual Lock, the model's location mark on the mat will contain boxes with Xs in it. For each X box, apply a piece of Dual Lock to the mat, adhesive side down. For half-sized boxes, if there are any, you will need to cut square pieces in half. Next, press (lock) a like-sized piece of Dual Lock, adhesive side up, onto to the ones you just finished sticking to the mat.

Tip: The second piece of each Dual Lock pair would rather stick to you than lock to its partner. So, instead of using your bare finger, press the second piece onto the first using the wax paper, which the Dual Lock was supplied on. Then peel away the paper.

Finally, for each Dual Locked model, line the model up exactly over its location, being sure that all labeled features are facing as labeled. Carefully lower the model and press it down onto the Dual Lock. Try to press down on the lowest solid structure of each model instead of crushing the whole model. This application process for the Dual Lock is only needed once - later, the models can simply be locked onto the mat or unlocked.

Model Details

Levee Blocks (No Dual Lock) There are eight levee blocks. Five go in Base (anywhere), and for the remaining three, center each one, upright, on one of the thin red rectangle outlines bordering the pink grid area.

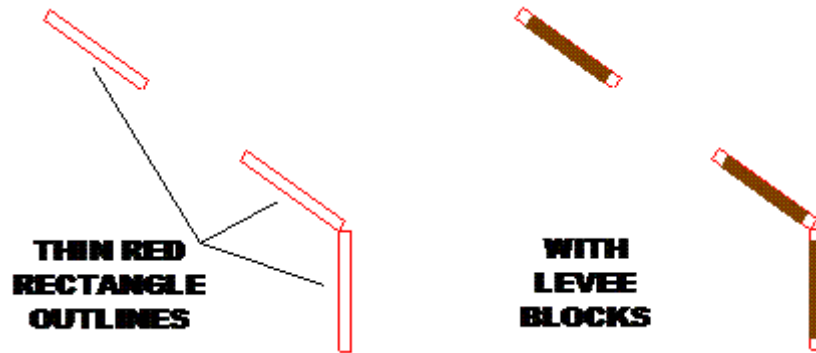

Storm (Wheel Roller) Place Dual Lock on its marks, position this model as shown on the mat, and stick it down.

Operation: When the perimeter bar is triggered, the vertical axle slides down, releasing the hammer (black hinged part) to fall, pushing the wheel out.

Setup: Lift the hammer until you can poke the vertical axle through its catch hole, and slowly let go of both. When that's done, carefully place the wheel over its image on the mat (No Dual Lock). This is designed to be an unstable setup, but it does work consistently when the model is built, placed, set, and maintained correctly. Make sure the hammer falls freely. If it doesn't, check to be sure there is free play along the hinge axle, that the red beams are parallel, and that they give the hammer clearance. Finally, be sure there's no Dual Lock touching the hammer.

People (No Dual Lock) There are six people, whose clothing determines their location. Those wearing:

- black, blue, or red shirts go in Base (anywhere).
- black pants go on their marks in the research area, with their ski poles generally downward.
- blue pants sit on their marks on the buildings, partly facing north, and each other.
- red pants are press-fit to stand on the northeast corner of the underground reservoir model, over their marks. Take note of where their marks are, because they will be covered out of view later.

As long as people with certain clothing are together where they need to be, their individual right/left placement is random. Faces and hair are not considered, but their hands should be near their pockets.

Underground Reservoir Before you proceed, notice that the northeast corner of the location mark for this model also has location marks for standing people. Memorize where those marks are, because you are about to cover them. Place Dual Lock on its marks, position this model on the mat, and stick it down.

Ice Sheet This model had to be changed after the mat went into production, so it does not line up perfectly with its location marks. At first, without Dual Lock, place each segment one at a time on its mark to see where the Dual-Lock location marks miss the model. Shift the Dual Lock as needed for full contact. With the new/correct Dual Lock locations in mind, place Dual Lock as needed, position the first segment, and stick it down. For each next

segment, make sure it is completely connected to the last one before sticking it down. Finally, without Dual Lock, place the little red, loopy ice core in its hole with its loop running parallel to the east border wall.

House Place Dual Lock on its marks, position this model on the mat as shown, and stick it down.

Setup: The house should be in the down position, with its large lever toward the west.

- Twist the wheel fully clockwise to close the south window.
- Twist the little red knob fully clockwise and pull it outward to set the lights “on” in the north window

Cross-Pointers (Interactive Models) Your table should have two border walls back to back at the north. Find the absolute center of these two walls.

- In the north/south direction, this point is the “crack” where the two walls touch.
- In the east/west direction, this point is 46.5in. (118.1cm) from the inside face of either far wall. Now measure east and west of this center point, 11in. (27.9cm) each way.

Each of these new points is the center point for one of the cross-pointer models. Cover the underside of each model’s foot completely with Dual Lock, align it and its rubber band parallel to the borders, and stick it down. If it does not sit level, add Dual Lock on the low side to level it.

Setup: Spin each arrow to a random direction. Any direction for either arrow is okay as long as the arrows do not agree with each other.

Flood Gate This model had to be changed after the mat was produced, so it does not line up perfectly with its location marks.

- The west side is good, so use that as normal.
- For the east side, apply Dual Lock to the model instead of the mat. Align the east side as accurately as possible, and stick it down.

Carbon Dioxide And Money (No Dual Lock) There are four carbon dioxides (gray balls) and one money (yellow ball). There is a holder (thin tire) for each. Place the following:

- A tire on each tire location mark
- A gray ball on each tire in the water
- The yellow ball on the tire in the green grid area

Core Drilling Rig (No Dual Lock) Place this model on its location mark, direction as shown on the mat.

Setup: The drill assembly part should be down/level.

Bicycle, Ice Buoy, Laptop, And Insulation (No Dual Lock) Place the bicycle, ice buoy, and laptop on their location marks, with directions of the bicycle and laptop as shown on the mat. Place the insulation (both) on its mark, one aligned on top of the other.

Bear And Snowmobile (No Dual Lock) Place the bear and snowmobile anywhere in Base with the five levee blocks and six people already there.

Field Maintenance

Border Walls

Remove any obvious splinters, and cover any obvious holes.

Field Mat

- Make sure the mat rests evenly at the bottom of the south and west border walls.
- Avoid cleaning the mat with anything that will leave a residue because anything sticky or slippery will affect the robot's performance compared to a new mat. Many tournaments use new mats.
- Use a vacuum and/or a damp cloth for dust and debris, above and below the mat.
- When moving the mat for transport and storage, be sure to prevent the material from bending into a sharp kink point, which could affect the robot's movement. Repeated rubbing on the same areas of your practice mat will cause wear in the image, but such wear is unlikely at a tournament.
- Tournaments using new mats should unroll the mats as far in advance of the tournament day as possible.
- For control of extreme curl at the east or west edges of the mat, tape is allowed, with a maximum of $\frac{1}{4}$ " (6 mm) overlap. Do not use tape under the mat.

Mission Models

Keep the models in original condition by straightening and tightening solid connections often. Ensure that spinning axles spin freely by checking for end-to-end play and replacing any that are bent.