

# 2009

# Field Setup

---

## OVERVIEW:

- ✓ The field is where the Robot Game takes place.
- ✓ It consists of a field mat, on a table, with mission models arranged on top.
- ✓ The field mat and the LEGO pieces for building the mission models are part of your Field Setup Kit.

---

## TABLE CONSTRUCTION

The Robot Game takes place on a specially designed table, so you'll need to build one to practice on if you don't already have access to one. With safety, weight, height, and cost in mind, a simple design is offered here, but as long as your surface is smooth, and your border walls are located properly, how you build the understructure is up to you. The construction is simple, but does require some wood-working skills.

At a tournament, two tables are placed back to back, but you only operate on one table, so you only need to build one table to practice on. Since a tournament setup has a double wall at the interactive area where the two tables meet, practice tables need an extra wall of type **B** on the corresponding side. So here are the instructions for building one "half-table" including a double north wall:

### Materials

Material	Quantity
Field Setup Kit (mission model LEGO elements, mat, CD, Dual Lock)	1
sanded plywood (or other very smooth board) 96" X 48" X 3/8" or thicker	1
two-by-four, 8' (actual cross-section = 1-1/2" by 3-1/2")	4
two-by-three, 8' (actual cross-section = 1-1/2" by 2-1/2")	2

flat black paint	1 pt. or spray can
coarse drywall screws, 6 X 2-1/2"	1/2 lb.
saw horses, about 24" high and 36" wide	2

### Parts

Part	Make From	Dimensions	Paint	Quantity
table surface (A)	plywood	96" X 48"	no	1
long border wall (B)	two-by-four	96"	yes	3
short border wall (C)	two-by-four	45"	yes	2
stiffener (D)	two-by-three	48"	no	4
saw horse	purchase	H » 24" W » 36"	no	2

### Assembly

**Step 1** - Determine which face of the plywood (A) is least smooth, and consider that the bottom face. On the bottom face, locate, clamp, and screw on the stiffeners (D) (about every 18 inches). Be sure screw head tops are flush. Sand any splinters.

**Step 2** - On the top face of the plywood, locate, clamp, and screw on the border walls (B,C) around the top perimeter. The wall-to-wall dimensions must measure  $93\pm 1/8"$  by  $45\pm 1/8"$  ( $2362\pm 3\text{mm}$  by  $1143\pm 3\text{mm}$ ).

**Step 3** - With the help of another person, place this table top on short saw horses (or milk crates, or anything else short and solid).

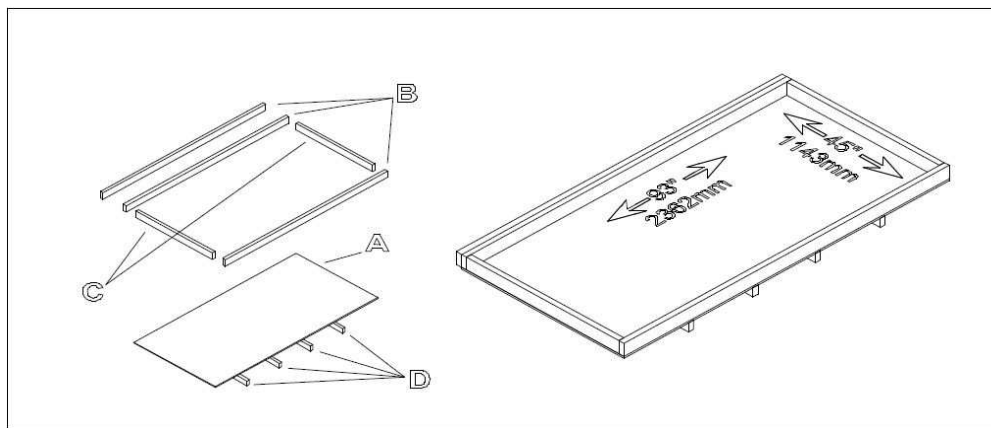

### FIELD MAT PLACEMENT

**Step 1** - Vacuum the table top. Even the tiniest particle under the mat can give the robot trouble. After vacuuming, run your hand over the surface and sand or file down any protruding imperfections you find. Then vacuum again.

**Step 2** - On the vacuumed surface (never unroll the mat in an area where it could pick up particles), unroll the mat so the image is up and its north edge is near the north/double border wall (note the location of the double wall in each table sketch below).

**Step 3** - The mat is smaller than the playing surface by design. Slide and align it so that there is no gap between the south edge of the mat and the south border wall. Center the mat in the east-west direction (look for equal gaps at left and right).

**Step 4** - With help from others, pull the mat at opposite ends and massage out any waviness away from the center and re-check the requirement of Step 3. It is expected that some waviness will persist, but that should relax over time. Some teams use a hair dryer to speed the relaxation of the waviness.

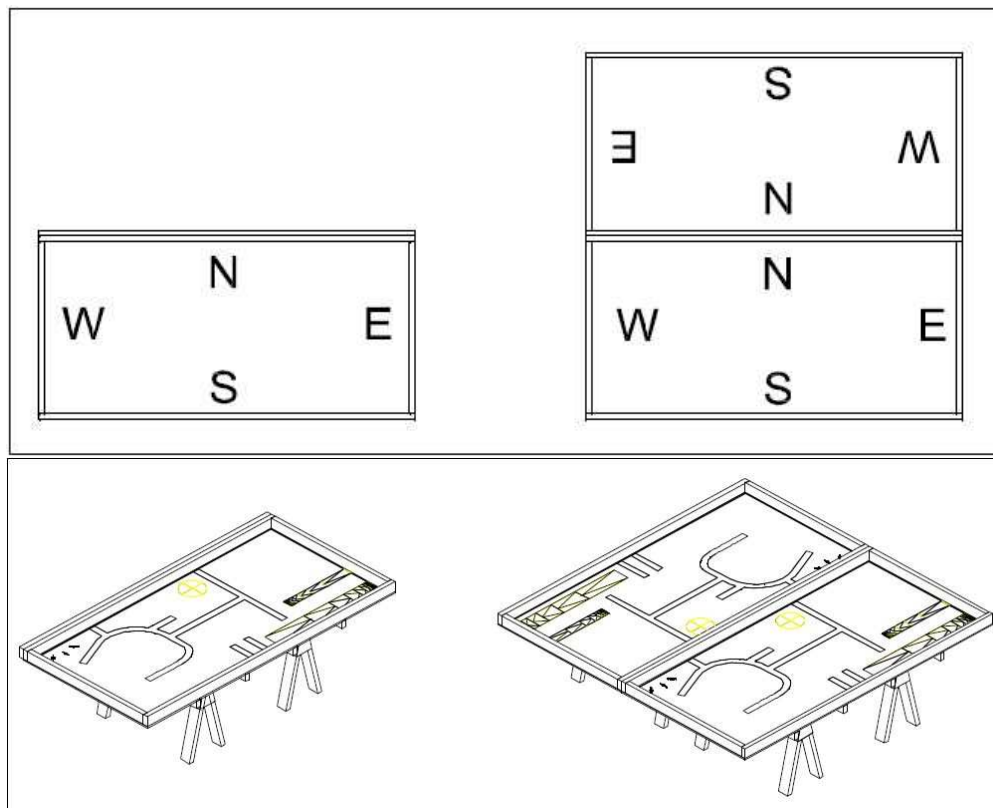

---

### **MISSION MODEL CONSTRUCTION**

Build the mission models - Use the LEGO elements and instruction CD from your Field Setup Kit. It should take a single person between two and three hours to do this, so it's best done in a work party. If there are any team members with little or no experience building with LEGO elements, mission model construction is a great way to learn. This step is also a nice time for new team members to get acquainted with each other.

---

## MISSION MODEL ARRANGEMENT - DUAL LOCK

### Dual Lock

For models where “Dual Lock Needed” appears in the mission model details below, that means the model needs to be secured to the mat during use. The connection is made using the re-usable fastening material from 3M called Dual Lock, which comes in the flat clear bag with the LEGO elements in your Field Setup Kit. Dual Lock is designed to stick or “lock” to itself when two faces of it are pressed together, but you can unlock it too, for ease of transport and storage. The application process for the Dual Lock is only needed once. Later, the models can simply be locked onto the mat or unlocked. To apply Dual Lock:

**Step 1** - Stick one square, adhesive side down, on each box you see on the mat with an “X” in it.

**Step 2** - Press a second square on top of each of those, “Locking” them on, adhesive side up. TIP: Instead of using your finger, use a bit of the wax paper the squares came on.

**Step 3** - Lower the model onto the squares.

**CAUTION** - Be sure to place each square precisely on its box, and each model precisely over its marks.

**CAUTION** - When pressing a model down, press down on its lowest solid structure instead of crushing the whole model. Pull on that same structure if you later need to separating the model from the mat.

**TIP:** For large/flexible models, apply only one or two sets at a time.

---

## MODEL DETAILS - -RIDGE

**Bridge** - Dual Lock Needed - Get familiar with the bridge’s exact placement before applying Dual Lock, then apply Dual Lock at one or two locations at a time, from south to north. After the six mat contacts are done, use three Dual Lock pairs to secure the red deck to the border wall (one pair at each end, and one pair at center). Prop up the hinged black deck by standing its swivel beam’s end on the tiny black mark.



---

### MODEL DETAILS - CRASH-TEST RAMP

**Crash-Test Ramp** - Dual Lock Needed - CAUTION: Be sure to not distort this model as you secure it. Set the hinged fence-like structure vertical (with the red beam being at its highest point as can be determined by eye).

---

### MODEL DETAILS - TRUCK

**Truck** - (NO Dual Lock) - The truck is pointed down the ramp with its rear axle being held by the ramp's red beam. The truck should be centered side-to-side on the ramp, and parallel to it. The truck's centering and parallelism should be as perfect as can be determined by eye, with the understanding that imperfection here adds expected/acceptable variability to the game.

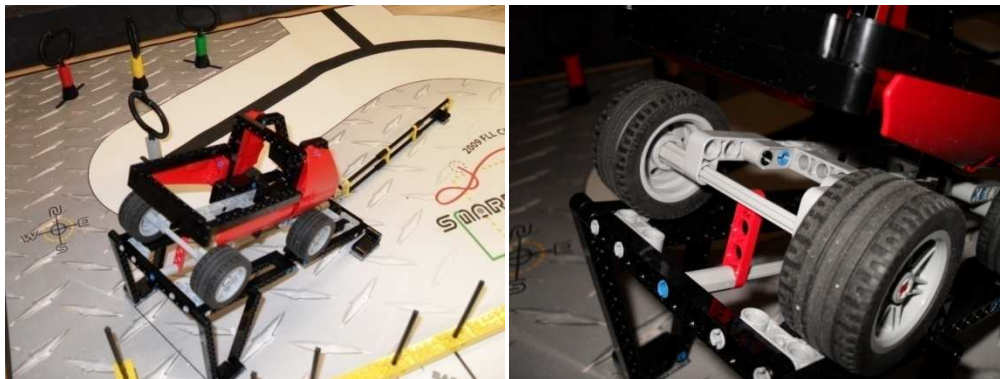

---

### MODEL DETAILS - ACCESS MARKERS

**Access Markers** - Dual Lock Needed – The access markers are directional. Be sure to place their oval feature over their mark on the mat. Once each model is secured, it needs to be “set.” Pull up on the green wheel, wait a few seconds until the black bumper stops swinging, then lower the wheel. A ball under the center of the bumper will settle into a cup. The exact rotation of the bumper is variable, but be sure there is some free space around the solid post/axle.



---

### MODEL DETAILS - GUIDE WALLS

**Guide Walls** - Dual Lock Needed - Two guide walls are placed in the southeast, and one is just north of Base. Quite simple!

---

### MODEL DETAILS - DYNAMOMETER

**Dynamometer** - Dual Lock Needed - This model is in the middle of the east half of the field, and both ends are identical. After pressing it down, test to be sure its rollers spin freely. If they don't, be sure the model is pressed all the way down evenly, be sure there is north-south free-play for the axles, and be sure they're not bent.

---

### MODEL DETAILS - SENSOR WALLS

**Sensor Walls** - (NO Dual Lock) - Stand four sensor walls on their marks in the northeast, studs up. The last one lies flat across the tops of the three tall black cylindrical columns. Place the square bases of those columns on their marks west of the bridge, toward the north, then carefully balance the sensor wall on top, with its studs facing south.

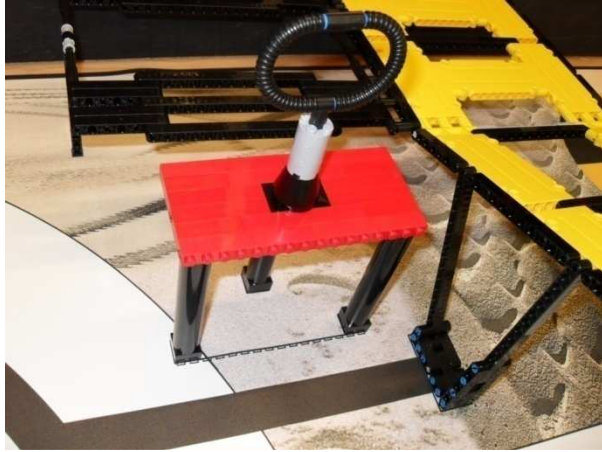

---

### MODEL DETAILS - WARNING BEACONS

**Warning Beacons** - (NO Dual Lock) - Stand each of the eight warning beacons on its small black circle, studs up. Five go between Base and the bridge, and three are just north of the east guide wall.

---

### MODEL DETAILS - LOOPS

**Loops** - (NO Dual Lock) - There are eleven loops. Eight of them stand on the mat on their corresponding colored marks with their loops aligned as each mark shows. The remaining two gray and one red are placed on other models, with their loops aligned parallel to the long border walls as follows: Stand one gray loop centered on the sensor wall which is on columns. Stand the other gray loop centered on the southwest axle of the south guide wall. Stand the red loop centered on the east-most axle of the south guide wall. Be sure all loops are vertical.

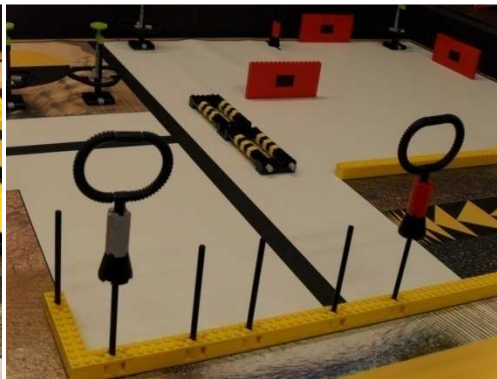
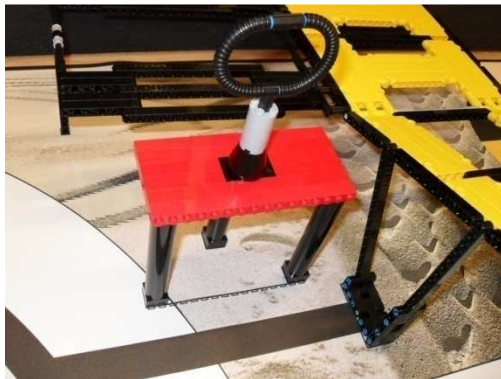

## MODEL DETAILS - PEOPLE AND CRASH-TEST FIGURE

**People and Crash-Test Figure** - (NO Dual Lock) - Place these five models in Base. Their exact position is unimportant.

---

## FIELD MAINTENANCE

- **Border Walls** - Remove any obvious splinters, and cover any obvious holes.
- **Field Mat** - Make sure the mat touches the south border wall, and is centered east to west. Avoid cleaning the mat with anything that will leave a residue. Any residue, sticky or slippery, will affect the robot's performance compared to a new mat (many tournaments use new mats). Use a vacuum and/or damp cloth for dust and debris (above and below the mat). When moving the mat for transport and storage, be sure not to let it bend into a sharp kink point, which could affect the robot's movement. Tournaments using new mats should unroll the mats as far in advance of the tournament day as possible. For control of extreme curl at the east or west edges of the mat, tape is allowed, with a maximum of  $\frac{1}{4}$ " (6 mm) overlap. Foam tape is not allowed.
- **Mission Models** - Keep the models in original condition by straightening and tightening solid connections often. Ensure that spinning axles spin freely by checking for end-to-end play and replacing any that are bent.